

JUMP KING[®]

Trampolines

User Guide

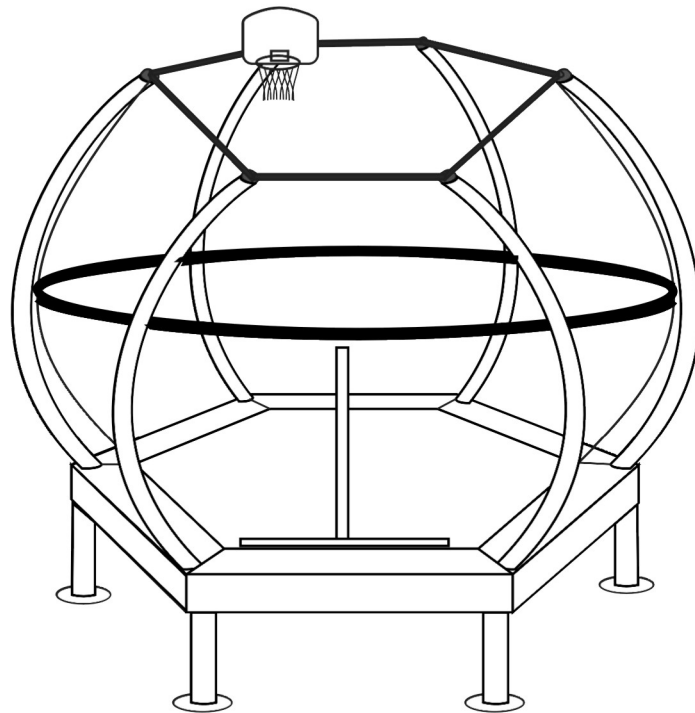

7ft Hexagonal ZorbPOD Trampoline & Enclosure

Model: JK7HXZP

The trampoline / enclosure is designed for users weighing 82 kg (180 lbs) or less.

**Got a Problem building your trampoline?
Please contact us at contact@jumpking.com**



WARNING: Read these assembly instructions carefully before attempting to assemble or use this product. Keep this user guide in a safe place for future reference.

JUMPKING®

7ft Hexagonal ZorbPOD Trampoline & Enclosure

Model: JK7HXZP

QUESTIONS?

If you have questions after reading this manual, please email us at contact@jumpking.com. The trained technicians will provide immediate assistance.

REPLACEMENT PARTS

To order replacement parts, please visit our website at www.jumpking.com.

More detailed instructions on assembling their trampoline may be available on www.jumpking.com in the Manual and Assembly section.

CONTENTS

IMPORTANT PRECAUTIONS	4
PART LIST	6
ASSEMBLY	7
CARE AND MAINTENANCE	18

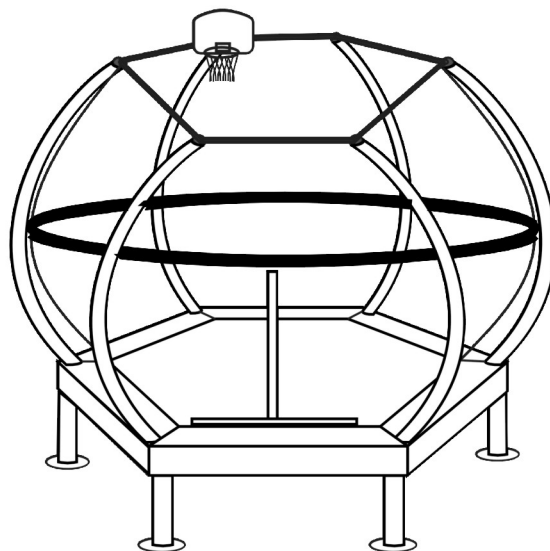

IMPORTANT PRECAUTIONS

⚠ WARNING: To reduce the risk of serious injury, read and follow all warnings, precautions, and instructions in this manual before assembling and using the trampoline.

This product is intended for use by children above 3 years of age.

This enclosure is to be used only in connection with this trampoline.

Read and follow all warnings and instruction.

This product is intended to be assembled by an adult.

Maximum weight limited 82 kg / 180 lbs.

Warning! Not suitable for children under 36 months. Small parts and long cords may be a choking and stragunation hazard.

BUILDING YOUR TRAMPOLINE

1. This is a 2 person build.
2. Time for build is approximately 2 hours.
3. Choose a good location:
 - On a level surface that is soft (*wood chippings, sand or grass*).
 - Ensure adequate overhead clearance. A minimum of 24ft (7.3m) from ground level, away from wires, trees and other possible hazards.
 - Ensure a clear space of 8.2ft (2.5m) around sides, away from walls, fences, structures, roads and other hard surfaces and play areas.

WHAT YOU WILL NEED

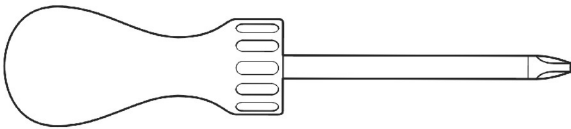

Description:
Cross-head screwdriver

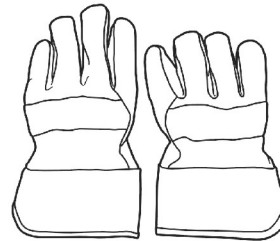

Description:
Gloves

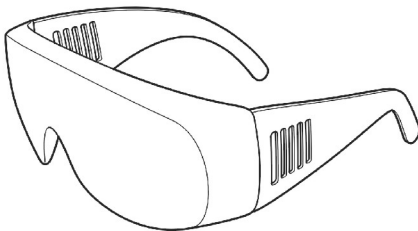



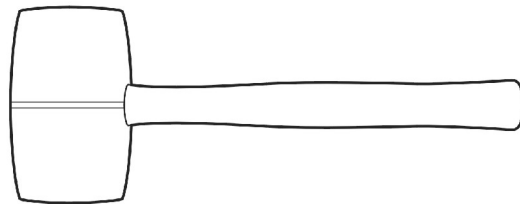







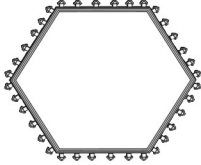

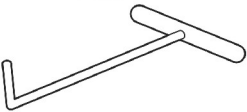
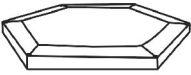
Description:
Safety glasses

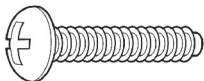
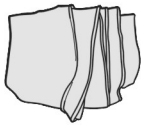
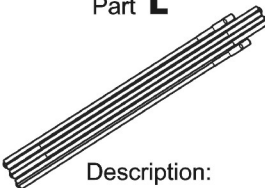
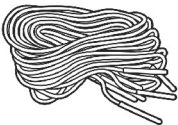
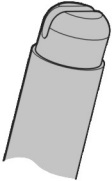

Description:
Mallet

PARTS LIST

<p>Part A</p>  <p>Description: Top Tube with T-Connector</p> <p>Quantity:6</p>	<p>Part B</p>  <p>Description: Straight Leg</p> <p>Quantity:6</p>	<p>Part C</p>  <p>Description: Plastic foot cap</p> <p>Quantity:6</p>	<p>Part D</p>  <p>Description: Stitched bed</p> <p>Quantity:1</p>
<p>Part E</p>  <p>Description: Springs</p> <p>Quantity:36</p>	<p>Part F</p>  <p>Description: Spring tool</p> <p>Quantity:1</p>	<p>Part G</p>  <p>Description: Frame pad</p> <p>Quantity:1</p>	<p>Part H</p>  <p>Description: Top enclosure poles</p> <p>Quantity:6</p>
<p>Part I</p>  <p>Description: Bottom enclosure poles</p> <p>Quantity:6</p>	<p>Part J</p>  <p>Description: Self tapping screws</p> <p>Quantity: 14 2 for spare use</p>	<p>Part K</p>  <p>Description: Enclosure netting</p> <p>Quantity:1</p>	<p>Part L</p>  <p>Description: Black G3 poles</p> <p>Quantity: 1</p>
<p>Part M</p>  <p>Description: Cords</p> <p>Quantity:4</p>	<p>Part N</p>  <p>Description: Caps for enclosure pole</p> <p>Quantity: 6</p>	<p>Part O</p>  <p>Description: Basketball Hoop</p> <p>Quantity: 1</p>	<p>Part P</p>  <p>Description: Plastic Clips</p> <p>Quantity: 2</p>
<p>Part Q</p>  <p>Description: Ball</p> <p>Quantity: 1</p>	<p>Part R</p>  <p>Description: Inflator & Needle</p> <p>Quantity: 1</p>	<p>Part S</p>  <p>Description: Zip Tie</p> <p>Quantity: 1</p>	

STEP 1 : ASSEMBLING THE FRAME

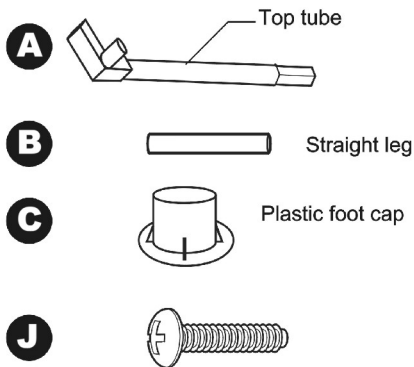

You will need the following parts to complete section 1:

6 x Top Tubes with T-connector - **Part A**

6 x Straight leg - **Part B**

6 x Plastic foot cap - **Part C**

6 x Self-tapping screw - **Part J**

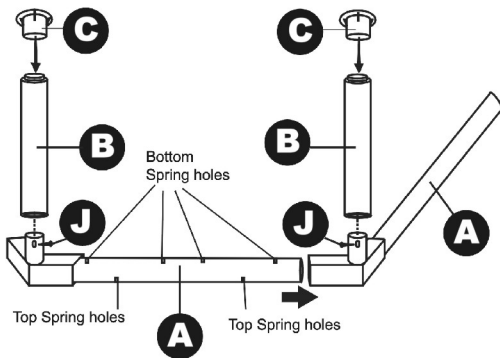

First we will complete one of the three sections of the trampoline frame.

Slot the narrow end of the top tube with T-connector into another top tube with T-connector.

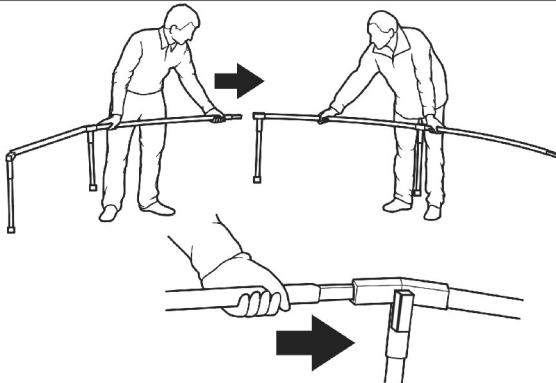

This step will require 2 people who must be wearing gloves.

Slot two of the frame section together as shown in the diagram.

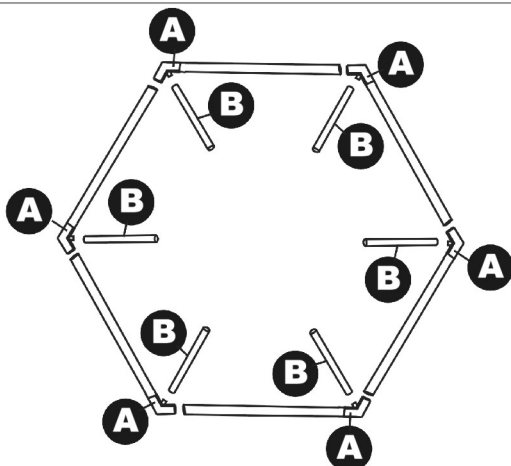

Important: Ensure all of the top tubes, leg extensions and centre legs are fully inserted.

The frame is now fully assembled and you have now completed step 1.

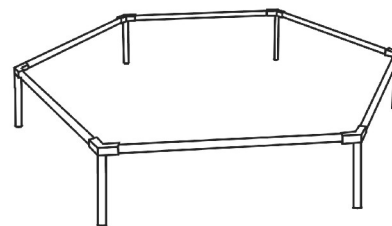

STEP 2 : FITTING THE STITCHED BED

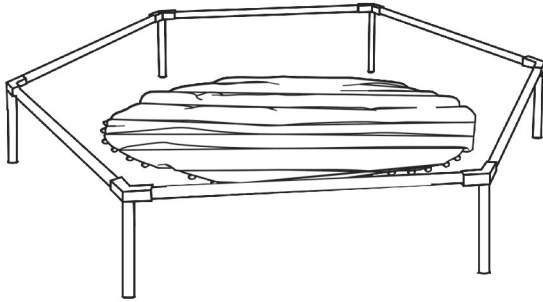

This step will require 2 people who must be wearing gloves and protective eye wear.

Lay the stitched bed (with the V-Rings) **part D** out inside the frame of the trampoline.

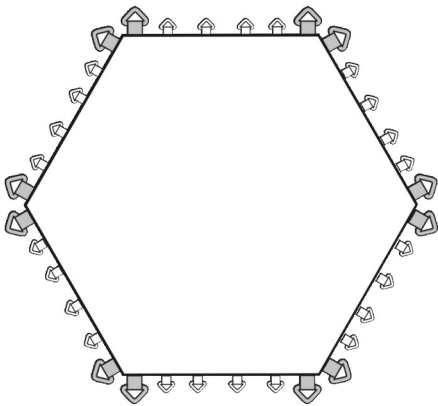

Locate the 12 V-Rings on corners.

These will be at 60° to each other.

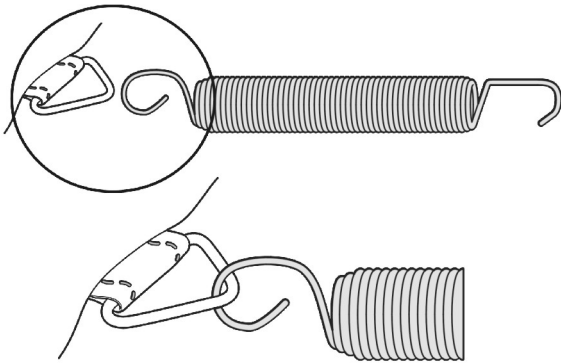

Slot one of the springs **part E** onto one of the webbing V-Rings as shown.

Important: springs must be slotted on the right way around.

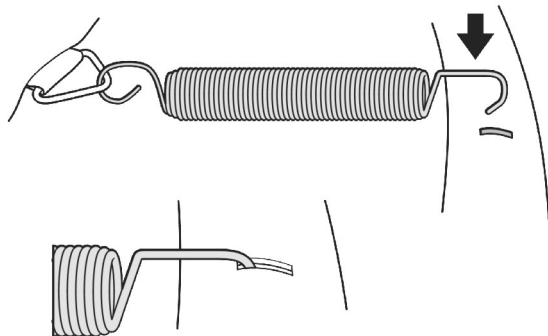

Slot the other end of the spring into one of the spring slots in the top of the frame.

IMPORTANT: Ensure the spring is fully inserted into the slot on the top of the frame.

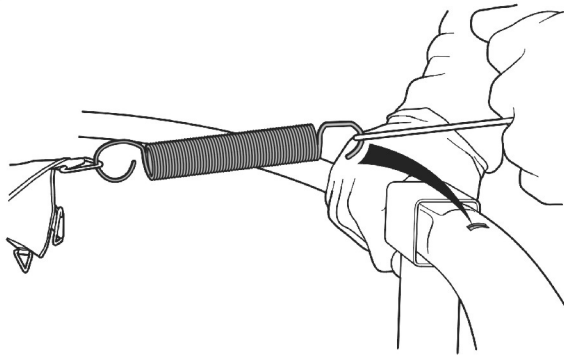

Attach a spring to the opposite of V-ring.

Important: You will now need to use the spring tool **part F** to attach the spring to the frame.

Hook the spring tool onto end of spring, and pull until the spring can be slotted into the spring slot on the top of the frame.

IMPORTANT: Ensure the spring is fully inserted into the slot on the frame.

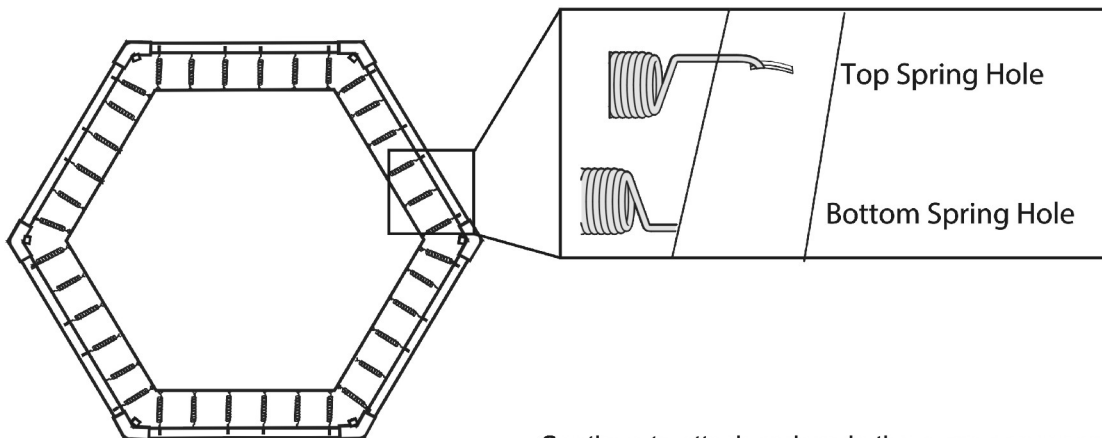
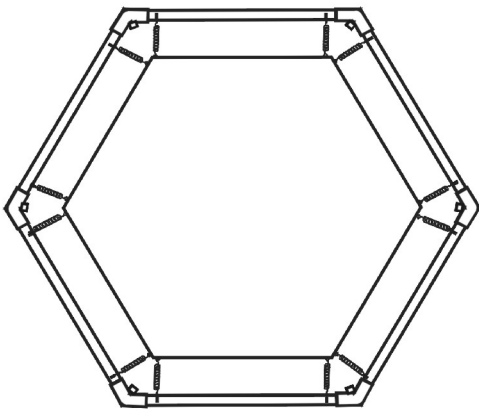

Continue to attach springs in the same sequence as above: in the middle of each section, making sure the next spring is attached on the opposite side to even out the tension.

Important: The stitched bed is designed like elastic to be bouncy, which means that during construction it may look like it won't fit. Please note that it will stretch to the correct size when attaching the springs, this may take some force.

The stitched bed is now fitted and you have completed step 2.

STEP 3 : FITTING THE FRAME PAD

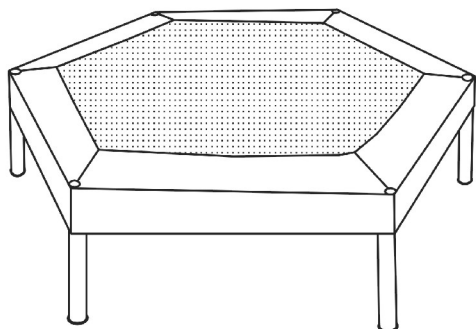

This step will require 2 people.

Lay the frame pad - **Part G** out over the edge of the frame with the ties facing downwards.

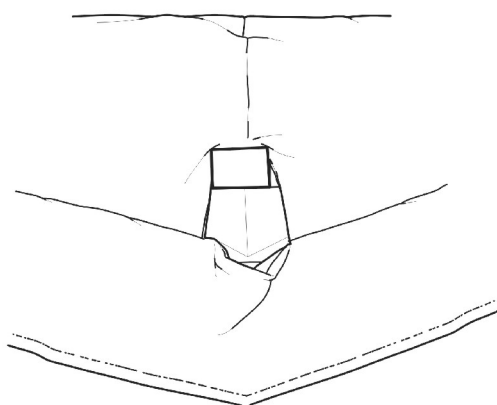

Align the openings in the frame pad with the T-connector's on the frame.

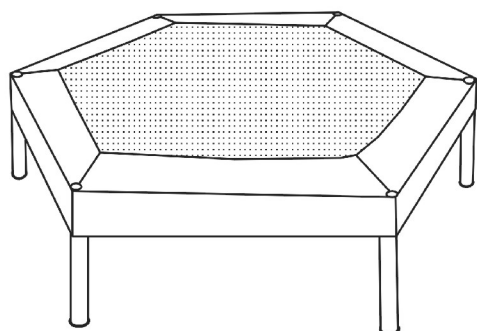

The frame pad is now fitted and you have completed step 3.

WARNING: The trampoline **MUST NOT** be used during construction.

STEP 4 : FITTING THE ENCLOSURE NETTING

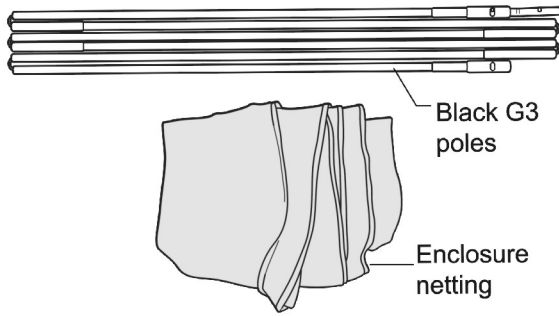

You will need the following parts to complete step 4:

1 x Enclosure netting - **Part K**

1 x Black G3 poles - **Part L**

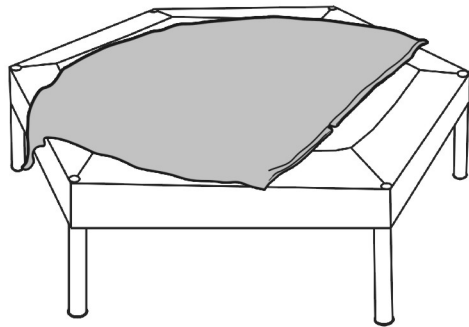

Lay the enclosure netting out on the trampoline.



Top of enclosure netting with ROD.

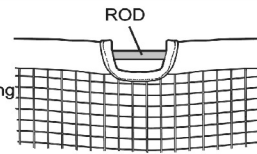

Upper sleeves for insert Top enclosure tubes.

Middle of enclosure netting with FRP sleeves.

Lower sleeves for insert Bottom enclosure tubes.

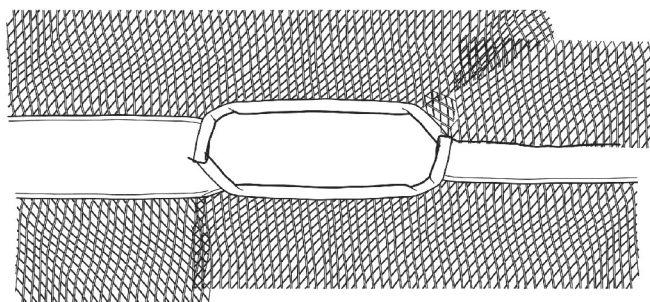

Find the sleeves that run along the middle of the enclosure netting.

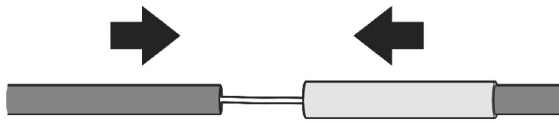

Slot the thin sections on the black G3 poles into the metal ends so the poles become two long sections.

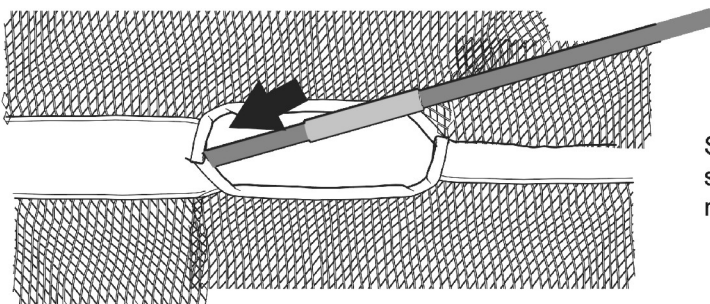

Slot the Black G3 poles through the sleeves on the middle of the enclosure netting.

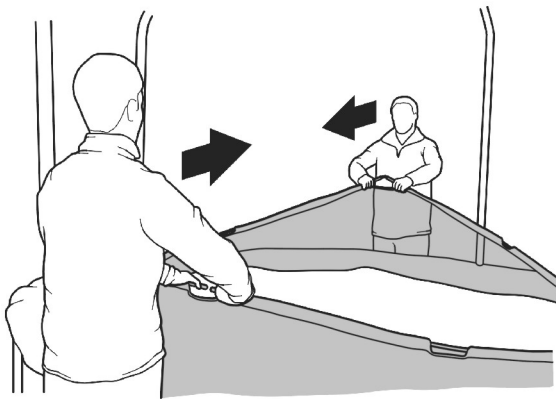

Y poles together with the fitted pole connectors, this will require two people.

Both people hold two of the poles end sections and walk towards each other to bend the poles into a circle.

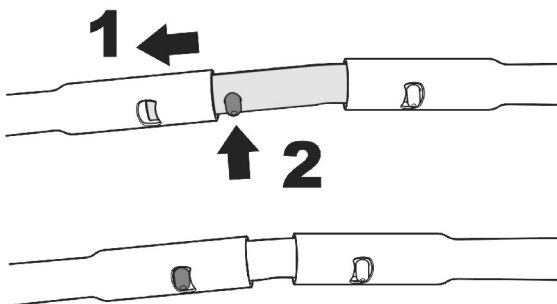

As soon as the poles are bent enough, insert the connectors into the socket on the other pole (1).

Push the pin inwards (2) and fully insert the connector.

Ensure the pin is protruding through the slot in the socket.

STEP 5: FITTING THE ENCLOSURE TUBES

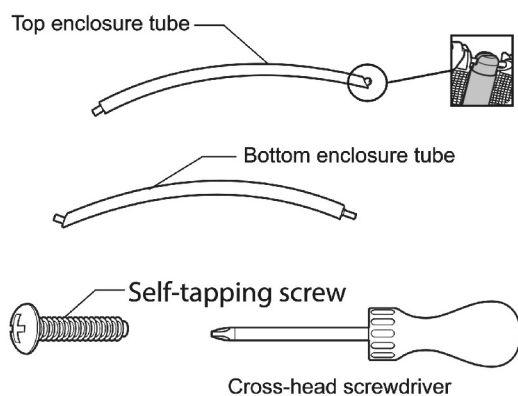

You will need the following parts to complete step 5:

6 x Top enclosure tubes - Part H

6 x Bottom enclosure tubes - Part I

6 x Self-tapping screw - Part J

You will also need a cross-head screwdriver (*not supplied*).

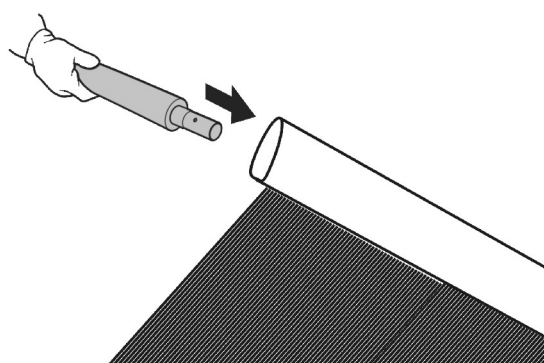

Slot the six bottom enclosure tubes into enclosure netting lower sleeves.

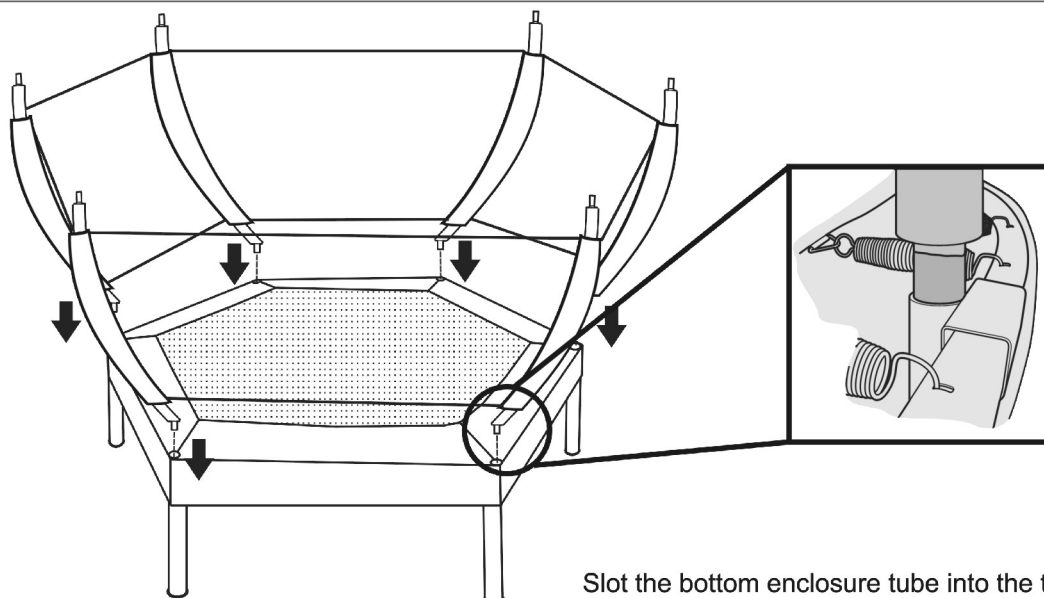

Slot the bottom enclosure tube into the tubes in the T-connector visible through the slots in the frame pad.

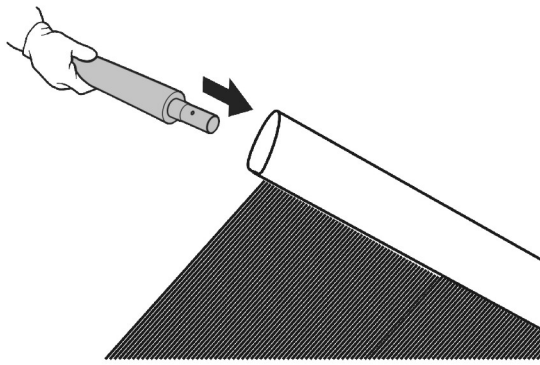

Slot the six top enclosure tubes into enclosure netting upper sleeves.

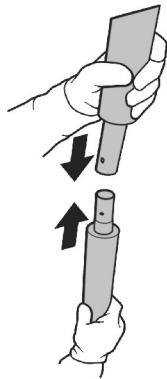

Slot the thin end of one of the bottom enclosure tubes into the open end of one of the top enclosure tubes.

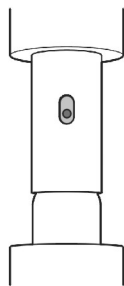

Align the hole in the bottom enclosure tube with the slot in the top enclosure tube.

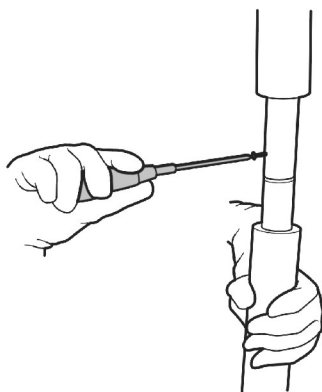

Screw one of the self tapping screws through the slot in the top enclosure tube and into the hole in the bottom enclosure tube using the cross-head screwdriver.

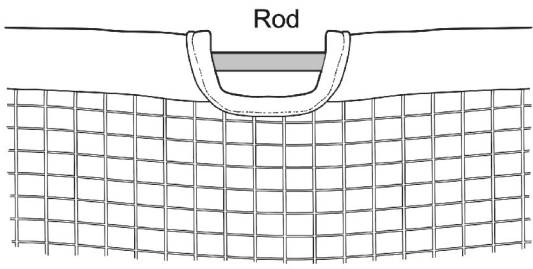

Find the ROD on top of enclosure netting.

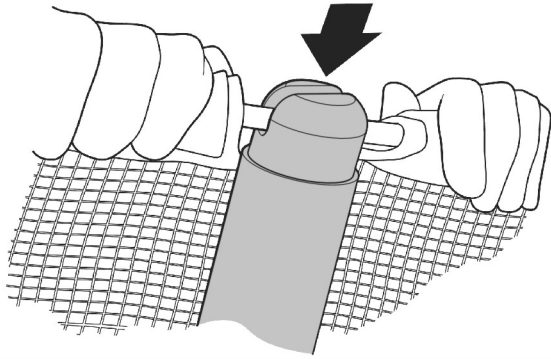

Stand on the trampoline and insert one of the exposed sections of the rod into a plastic grip on top of one of the enclosure tubes.

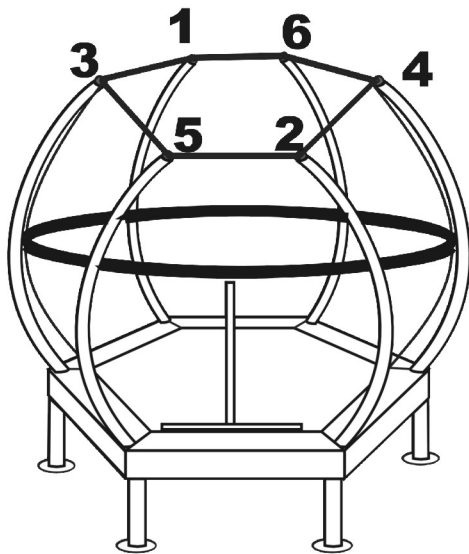

Attach the three other exposed sections of the rods to the other enclosure tubes in the order shown in the diagram.

The enclosure net is now fitted and you have completed step 4.

STEP 6 : ATTACHING THE BOTTOM OF THE NET

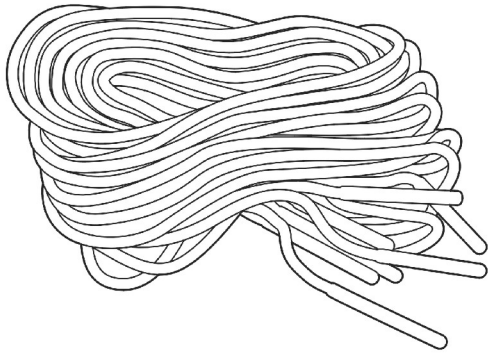

You will need the following parts to complete step 6:
4 x Cords - **Part M**.

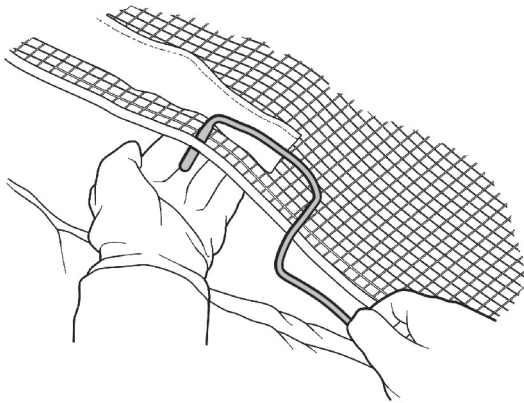

Tie the end of the cord around a V-Ring and loops. Push the end rope through a hole in the bottom of the netting.

Important: Keep the cord tight at all times.

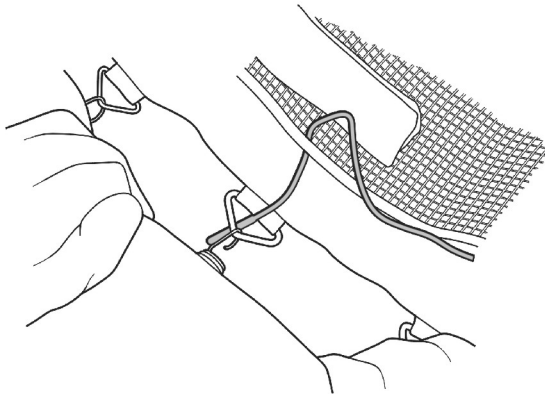

Slot end of the cord through the middle of the next V-Ring or loops along.

Now slot the end back through the net and down through the next V-Ring. Continue to do this until you have used up nearly all the cord then tie this end around a V-Ring.

Tie another cord to this V-Ring and continue until all of the net is tied down.

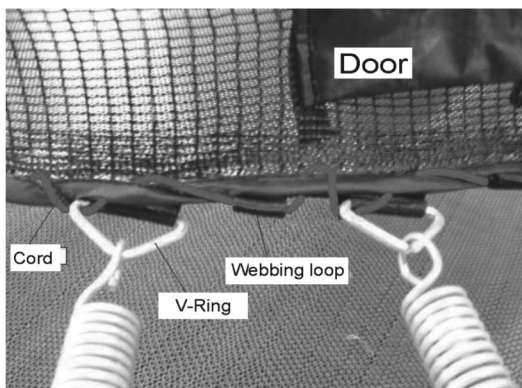

You have completed step 6 and the trampoline is fully assembled.

STEP 7 : ATTACHING THE BASKETBALL HOOP

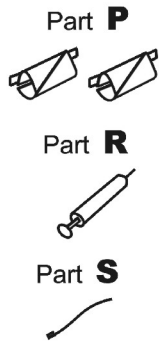

You will need the following parts to complete step 6:

1 x Basketball Hoop - **Part O**

2 x Plastic Clips - **Part P**

1 x Ball - **Part Q**

1 x Inflator - **Part R**

1 x Zip Tie - **Part S**

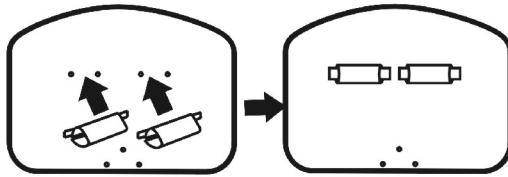

Place the Plastic Clips onto back of Basketball Board.

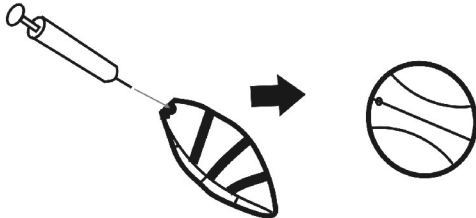

Use Inflator to inflate the ball.

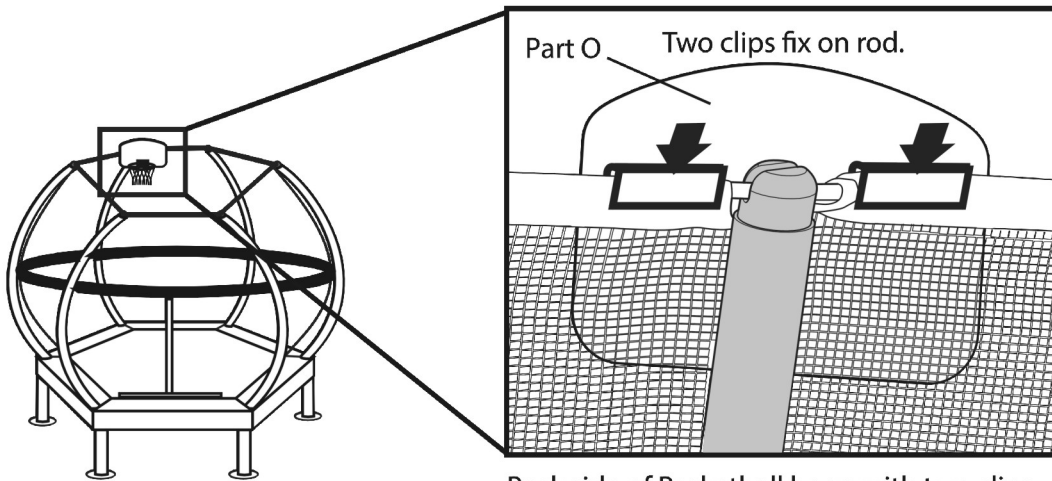

Back side of Basketball hoop with two clips. Please fix onto top rod of enclosure.

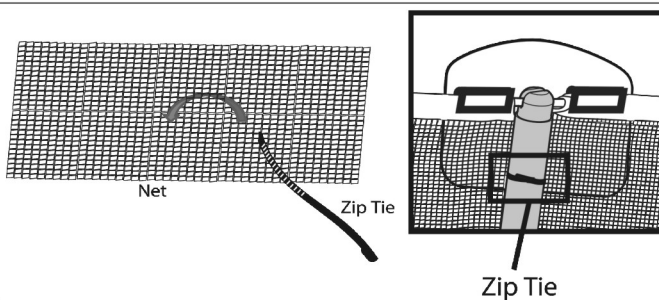

Insert the Zip Tie through the hole of net then tie on top enclosure pole.

CARE AND MAINTENANCE

Care

Do not allow pets or animals on the trampoline or inside the enclosure, as claws may snag and pull the bed material or damage the frame pad or netting.

The trampoline/enclosure is intended to be used by one person at a time weighing 82kg(180lbs) or less. The user should be either barefoot or wearing socks.

Street shoes or tennis shoes should not be worn on the trampoline. The user should remove all sharp objects from his or her person that may cause injury or damage to the bed. Heavy, sharp, or pointed hard objects should not contact the bed.

Maintenance

Your trampoline is manufactured using quality materials and crafted to provide your children with many years of enjoyment. Proper maintenance and care will help to prolong the life of the trampoline and reduce the possibility of injury.

Prolonged exposure to the sun, will shorten the life of the trampoline/enclosure fabric. For longer fabric life store the trampoline/enclosure when it is not being used. A dry trampoline/enclosure, properly stored, will provide the longest life of the fabric, sewing, and hardware. Remove the enclosure from the trampoline during harsh weather conditions or during long periods of non-use.

The following guidelines should always be observed. Inspect the trampoline/enclosure before each use, and replace any worn, damaged, or missing parts. The following conditions could represent potential hazards and increase the chance of personal injury:

- a missing, improperly positioned, or insecurely attached frame pad, netting, enclosure tubes, foam

sleeves.

- punctures, frays, tears, or holes worn in the bed, frame pad, netting, foam sleeves.
- deterioration in the stitching or fabric of the bed, frame pad, netting.
- broken or missing springs.
- a bent or broken frame, leg, enclosure poles.
- a sagging bed or netting.
- sharp protrusions on the frame, suspension system, enclosure tubes.

If any of these conditions exist, the trampoline should be disassembled or otherwise protected against use until the condition is corrected.

Removing and storing the trampoline/enclosure

Make sure that the trampoline/enclosure is dry before removing and storing it. Use caution while removing the tubes due to the weight of the tubes.

Once the enclosure is removed from the trampoline, remove all items from the trampoline bed. Make sure that the bed is clean and that it has no tears or holes. Store the trampoline/enclosure in a safe, dry location.

Moving the trampoline

If the trampoline/enclosure needs to be moved, it should be moved by two persons, kept horizontal, and lifted slightly. If necessary, the trampoline/enclosure can be disassembled for moving.

To disassemble the trampoline/enclosure, follow the assembly steps in reverse order (see pages 4 to 9). Do not attempt to disassemble the frame sections, legs or bases before the bed and springs have been removed.